



3P / 3H MANAGEMENT KIT

1/4" AND 3/8"

INSTALLATION GUIDE & INCLUDED COMPONENTS

FOR OFF-ROAD USE ONLY

www.bagriders.com

844.404.7344

© Bag Riders, LLC.

SINGLE COMPRESSOR WITH WATER TRAP(S)

@BAG RIDERS, LLC. — NOT TO SCALE

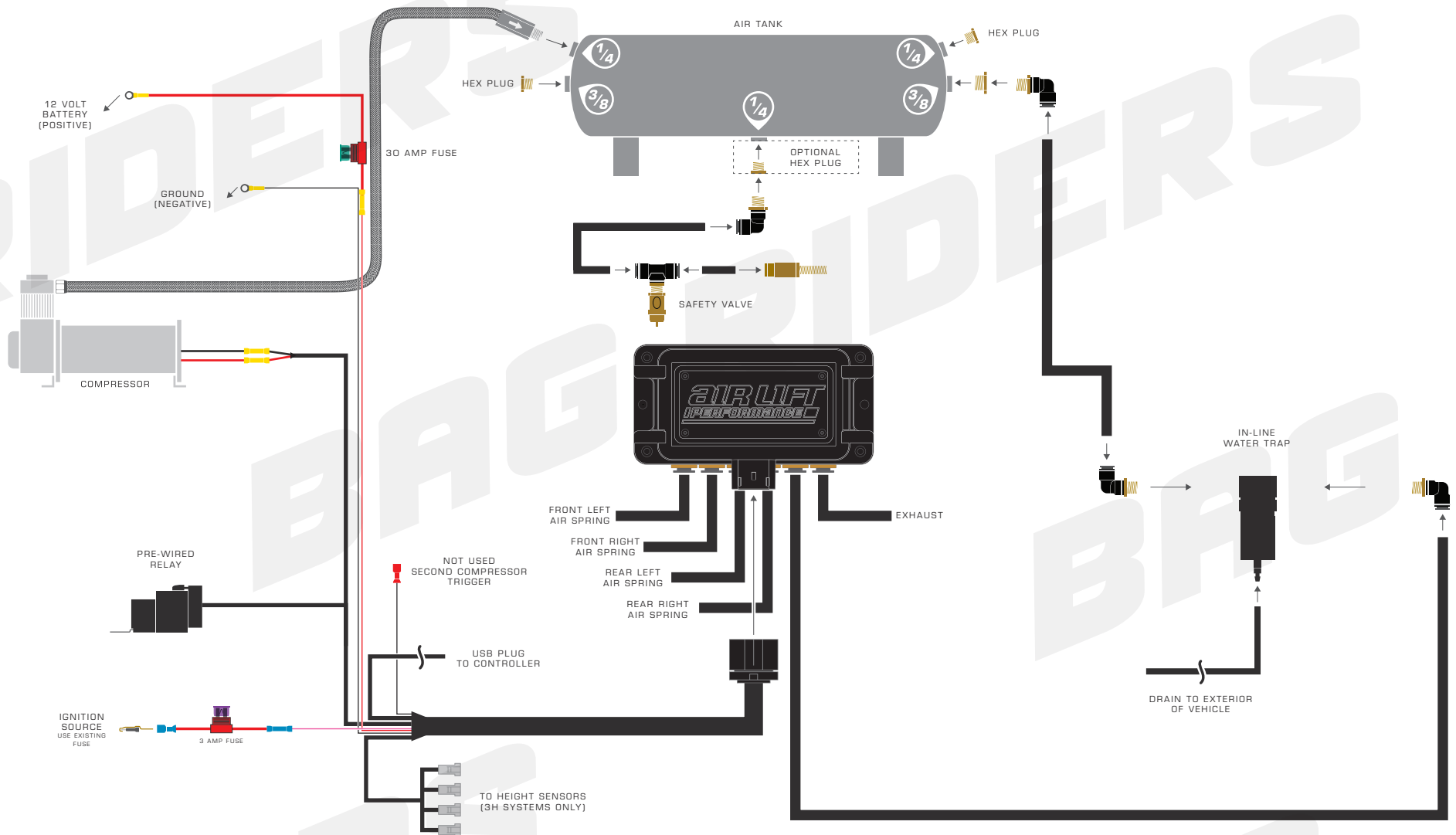

DUAL COMPRESSORS WITH WATER TRAP(S)

@BAG RIDERS, LLC. — NOT TO SCALE

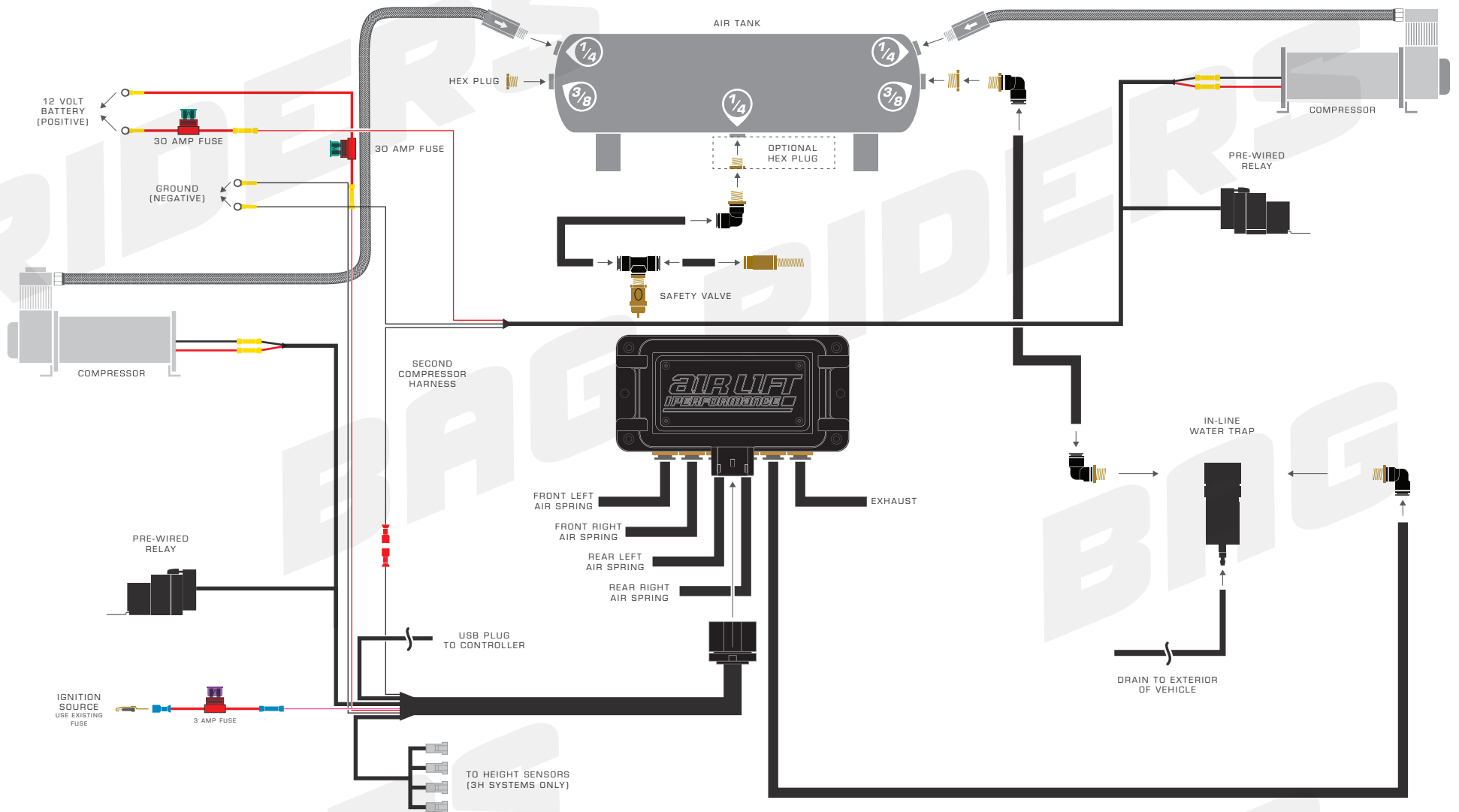

SINGLE OB2 COMPRESSOR WITH WATER TRAP(S)

@BAG RIDERS, LLC. — NOT TO SCALE

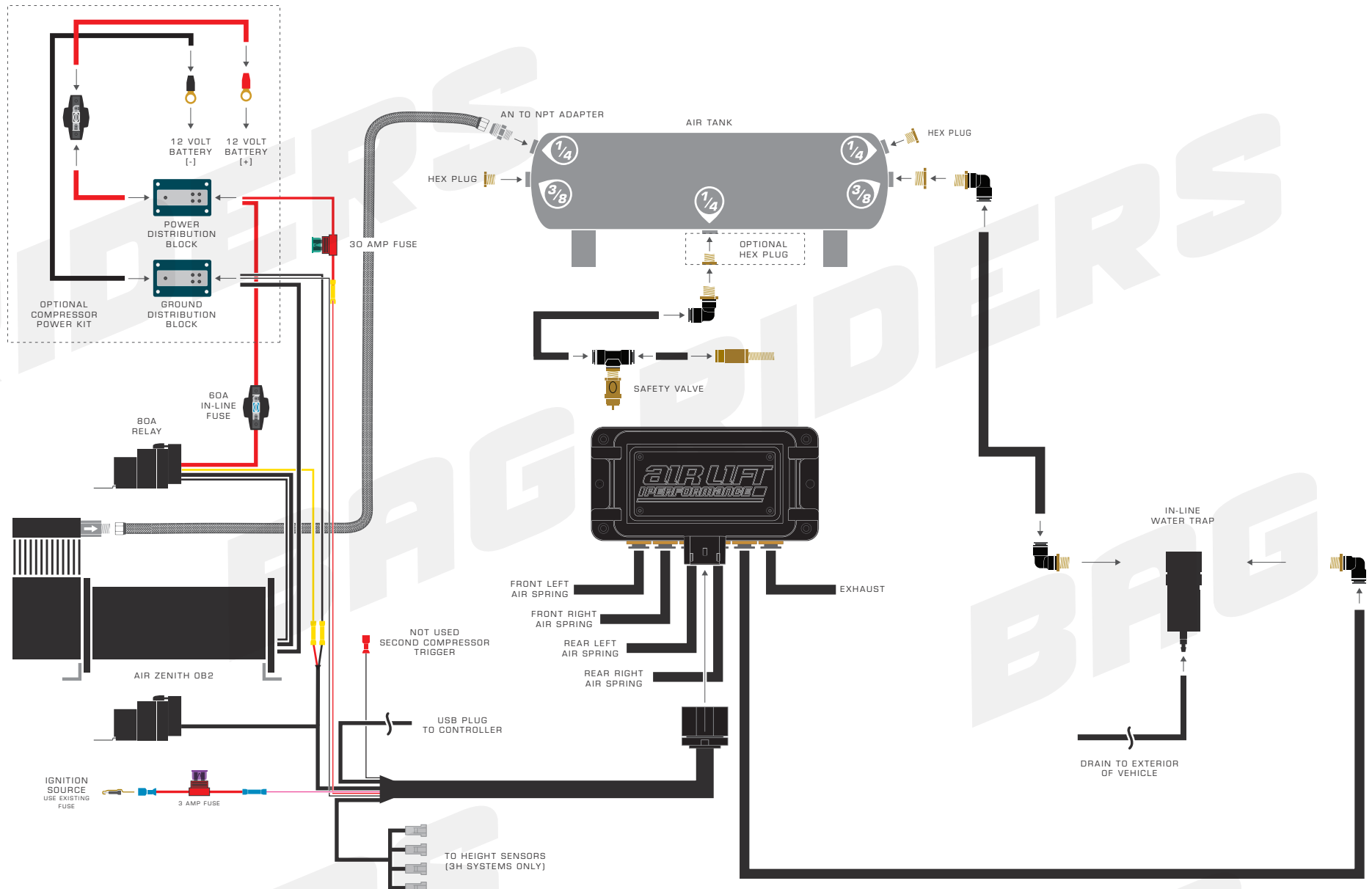

ENDO CT TANK (INTERNAL COMPRESSOR)

@BAG RIDERS, LLC. — NOT TO SCALE

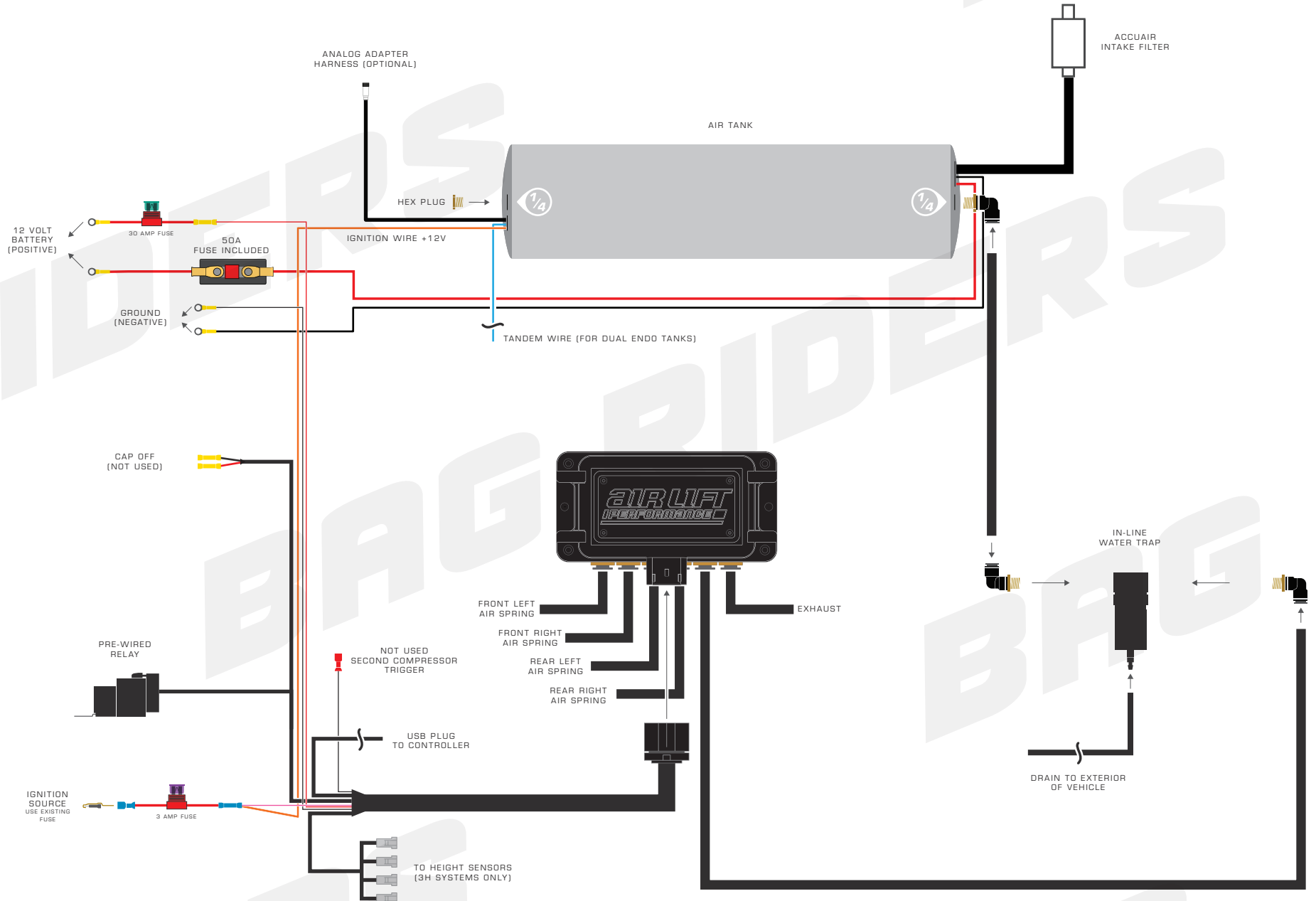

SMC REPLACEMENT CHECK VALVE

@BAG RIDERS, LLC. — NOT TO SCALE



REMOVE STANDARD VICI CHECK VALVE.

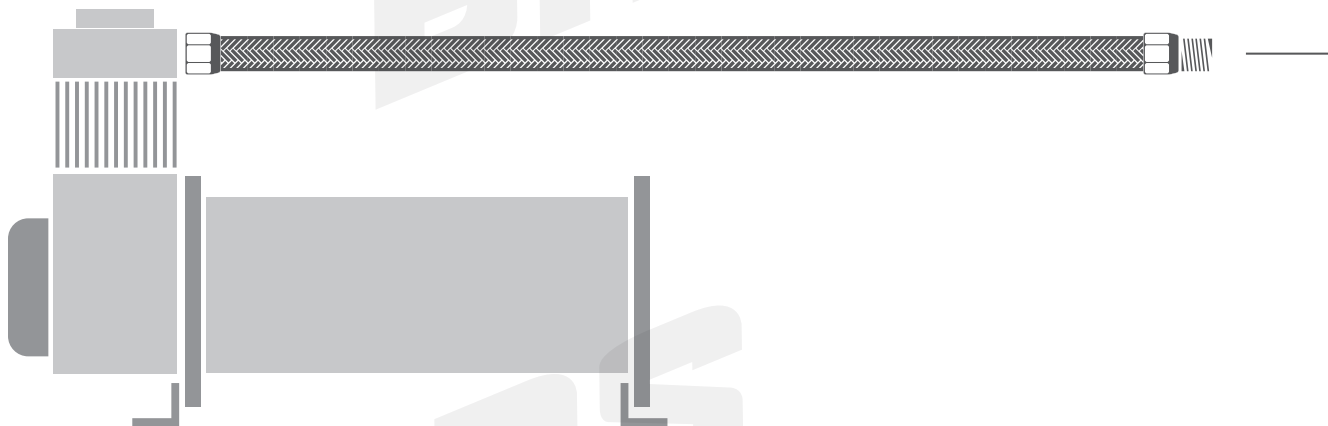

REPLACE WITH SMC CHECK VALVE

INCLUDED COMPONENTS

@BAG RIDERS, LLC. — NOT TO SCALE

AIR TANK



- 1 — Air Lift Aluminum 4 Gallon Tank
End-ports, Polished or Raw

COMPRESSOR

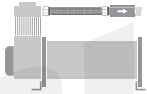

- 1 — VIAIR 400C Compressor

TANK DRAIN KIT



- 5 — Air Lift 1/4 Inch Air Line
By the Foot



- 1 — SMC Swivel Elbow
1/4" PTC to 1/4" NPT



- 1 — Air Lift Inflation Valve
1/4" PTC

IN-LINE WATER TRAP KIT



- 1 — Air Lift Water Trap
1/8" NPT in, 1/8" NPT Out



- 2 — SMC Male Straight
3/8" PTC (or 1/4" PTC) to 1/8" NPT

BAG RIDERS FITTING PACK



- 2 — Parker Brass Reducer
3/8" NPT to 1/4" NPT



- 2 — Parker Brass Hex Plug
1/4" NPT



- 1 — Parker Brass Hex Plug
3/8" NPT



- 2 — Parker Brass Street Elbow
1/4" NPT



- 2 — SMC Swivel Elbow
3/8" PTC or 1/4" PTC to 1/4" NPT



- 60 — Air Lift Air Line
By the Foot

- 1 — Line Cutter

- 1 — Thread Tape Roll